

Solar Power Purchase Agreement

This Solar Power Purchase Agreement (this “**Agreement**”) is entered into by the parties listed below (each a “**Party**” and collectively the “**Parties**”) as of the date signed by Seller below (the “**Effective Date**”).

Purchaser:	Town of Chebeague Island	Seller:	ReVision Investments, LLC, a Maine limited liability company
Name and Address	Town of Chebeague Island 192 North Road Chebeague Island, ME 04017 Attention: Marjorie Stratton, Town Administrator	Name and Address	ReVision Investments, LLC c/o ReVision Energy LLC 142 Presumpscot St. Portland, ME 04103 Attention: Sam Lavallee, Director of Financing
Phone	(207) 846-3148	Phone	(207) 221-6342
Fax	(207) 846-6413	Fax	(207) 221-1535
E-mail	TownAdmin@chebeague.net	E-mail	sam@revisionenergy.com
Premises Ownership	Purchaser [x] owns [] leases the Premises. List Premises Owner, if different from Purchaser:	Additional Seller Information	ReVision Investments, LLC is a wholly owned subsidiary of ReVision Energy LLC

This Agreement sets forth the terms and conditions of the purchase and sale of solar generated electric energy from the solar panel system described in **Exhibit 2** (the “**System**”), interconnected to the Purchaser’s facility described in **Exhibit 2** (the “**Facility**”), and installed on the property upon which the System and Facility are located as described in **Exhibits 5 and 6** (the “**Premises**”).

The exhibits listed below are incorporated by reference and made part of this Agreement.

- Exhibit 1** Basic Terms and Conditions
- Exhibit 2** System Description
- Exhibit 3** Credit Information
- Exhibit 4** General Terms and Conditions
- Exhibit 5** Form of Memorandum of License
- Exhibit 6** Form of License Agreement

Purchaser: Town of Chebeague Island

Seller: ReVision Investments, LLC

By (signature): _____

By: ReVision Energy LLC

Printed Name: _____

By: _____
Printed Name: Fortunat Mueller

Title: _____

Title: Managing Member, ReVision Energy LLC

Date: _____

Date: _____

Guaranty: As the sole owner of ReVision Investments, LLC, ReVision Energy LLC unconditionally guarantees performance of Seller’s obligations under this Power Purchase Agreement and any addendum thereto, and waives recourse to any guarantorship or suretyship defenses with respect to the same.

ReVision Energy LLC

By: _____
Fortunat Mueller, Managing Member

Exhibit 1
Basic Terms and Conditions

1. **Initial Term:** Twenty (20) years, beginning on the Commercial Operation Date.
2. **Additional Terms:** Up to two (2) Additional Terms of five (5) years each.
3. **Environmental Incentives and Environment Attributes:** Accrue to Seller, however Purchaser has the option to purchase Renewable Energy Credits (“RECs”) at the price (\$/MWH) and for the years specified below. RECs for any Contract Year not bought by Purchaser under this option will be sold to third parties.

Purchaser [] WILL purchase [x] WILL NOT purchase RECS as specified in this Exhibit 1, Section 4.

4. **Contract Energy Price per Kilowatt Hour (\$/kWh) and Optional REC Price per Megawatt Hour (\$/MWH):**

Contract Year	Estimated Energy Production (kWh)	Energy \$/kWh	REC \$/MWH
1	79,516	\$0.1265	N/A
2	79,118	\$0.1265	N/A
3	78,723	\$0.1290	N/A
4	78,329	\$0.1316	N/A
5	77,938	\$0.1342	N/A
6	77,548	\$0.1369	N/A
7	77,160	\$0.1396	N/A
8	76,774	\$0.1424	N/A
9	76,390	\$0.1453	N/A
10	76,009	\$0.1482	N/A
11	75,628	\$0.1511	N/A
12	75,250	\$0.1542	N/A
13	74,874	\$0.1572	N/A
14	74,500	\$0.1604	N/A
15	74,127	\$0.1636	N/A
16	73,757	\$0.1669	N/A
17	73,388	\$0.1702	N/A
18	73,021	\$0.1736	N/A
19	72,656	\$0.1771	N/A
20	72,292	\$0.1806	N/A

5. **Condition Satisfaction Date:** November 30, 2017
6. **Anticipated Commercial Operation Date:** December 31, 2017
7. **Rebate Variance.** All prices in this Agreement are calculated based on an upfront rebate of \$0. If the actual rebate is lower than calculated, prices will be adjusted pro-rata to reflect the actual rebate received.
8. **Purchaser Options to Purchase System.** [] None, or [x] As set forth in Section 17.b.
9. **Outside Commercial Operation Date:** December 31, 2018
10. **System Installation:**

Includes:	[x] Design, engineering, permitting, installation, monitoring, rebate application and paperwork processing of the System. [x] Limited Warranty [] List of Approved Subcontractors [x] Any like substantive equipment, in the sole discretion of the Seller. [] State or Utility Rebate, if any. Describe: N/A
Excludes:	Site preparation and unforeseen groundwork (including, but not limited to, excavation/circumvention of underground obstacles), utility impact study if applicable, payment bonds, performance bond(s), prevailing wage construction, tree removal, tree trimming, professional engineer’s stamp review if required by local or state permitting, or energy audit, if required.

End of Exhibit 1

Exhibit 2
System Description

1. **System Location:** Town Garage, Littlefield Road, Chebeague Island, ME 04017
2. **System Size:** 62.1 DC kW (panel nameplate capacity), 46.6 AC kW (inverter rating).
3. **Expected First Year Energy Production (kWh):** 79,516. Expected energy production shall be de-rated by one half of one percent (0.5%) annually. Annual energy production is based on maintenance of Insolation levels provided for in the Irradiance Zone and Shade Map and the Helioscope projections provided in Attachment A, below.
4. **Expected Structure:** Ground Mount Roof Mount Parking Structure Other
5. **Expected Module(s):**

<u>Manufacturer/Model</u>	<u>Quantity</u>
345W REC345-TP-2S 72 Cell, or equivalent, with 25-year manufacturer's performance warranty	180

6. **Expected Inverter(s):**

<u>Manufacturer/Model</u>	<u>Quantity</u>
SMA SB7.7-ISP-US-40, or equivalent, with 10-year manufacturer's performance warranty	6

7. **Facility and System Layout:** See Exhibit 2, Attachment A
8. **Utility:** Central Maine Power
9. **Participating Meters:**
 - i. Town Garage, CMP Meter - G046555567; CMP Account - 441-156-0630-002.
 - ii. Chandler's Cove, CMP Meter - G045541247; CMP Account - 441-167-9727-002.
 - iii. Town Hall, CMP Meter - G045538072; CMP Account - 441-144-5156-013.
 - iv. Stone Wharf, CMP Meter - G045539343; CMP Account - 441-173-9247-003.
 - v. Transfer Station, CMP Meter - G045294319; CMP Account - 441-152-2696-002.
 - vi. Chebeague Island School, CMP Meter - G045541489; CMP Account - 441-144-4877-012.
 - vii. New service, CMP Meter tbd, to interconnect System.

Exhibit 2
Attachment A:
Facility and System Layout

Aerial Image of Facility	See Sheet A01, Site Map, below.
Conceptual Drawing of the System	See Sheet E01, One-Line Drawing, below.
Location of System Components	Solar array to be located as a ground mount at the Town Public Works Facility and Transfer Station as portrayed in site map. Inverters to be located at array or other location as agreed upon by the Parties.
Delivery Point	On utility side of private SolarLog 1200 revenue grade meter/data logger as shown in Sheet E01, One-Line Drawing, below.
Access Points	Access shall be by existing drives and ways and as mutually agreed by the Parties. Access shall be adequate to allow full and timely access to the facility for installation and maintenance. See also Sheet A01, Site Map, below.
Irradiance Zone	Removal of vegetation and prevention of shading to protect the irradiance zone for the system shall conform to the specifications set forth in the Irradiance Zone and Shade Map, below.

Site Map:

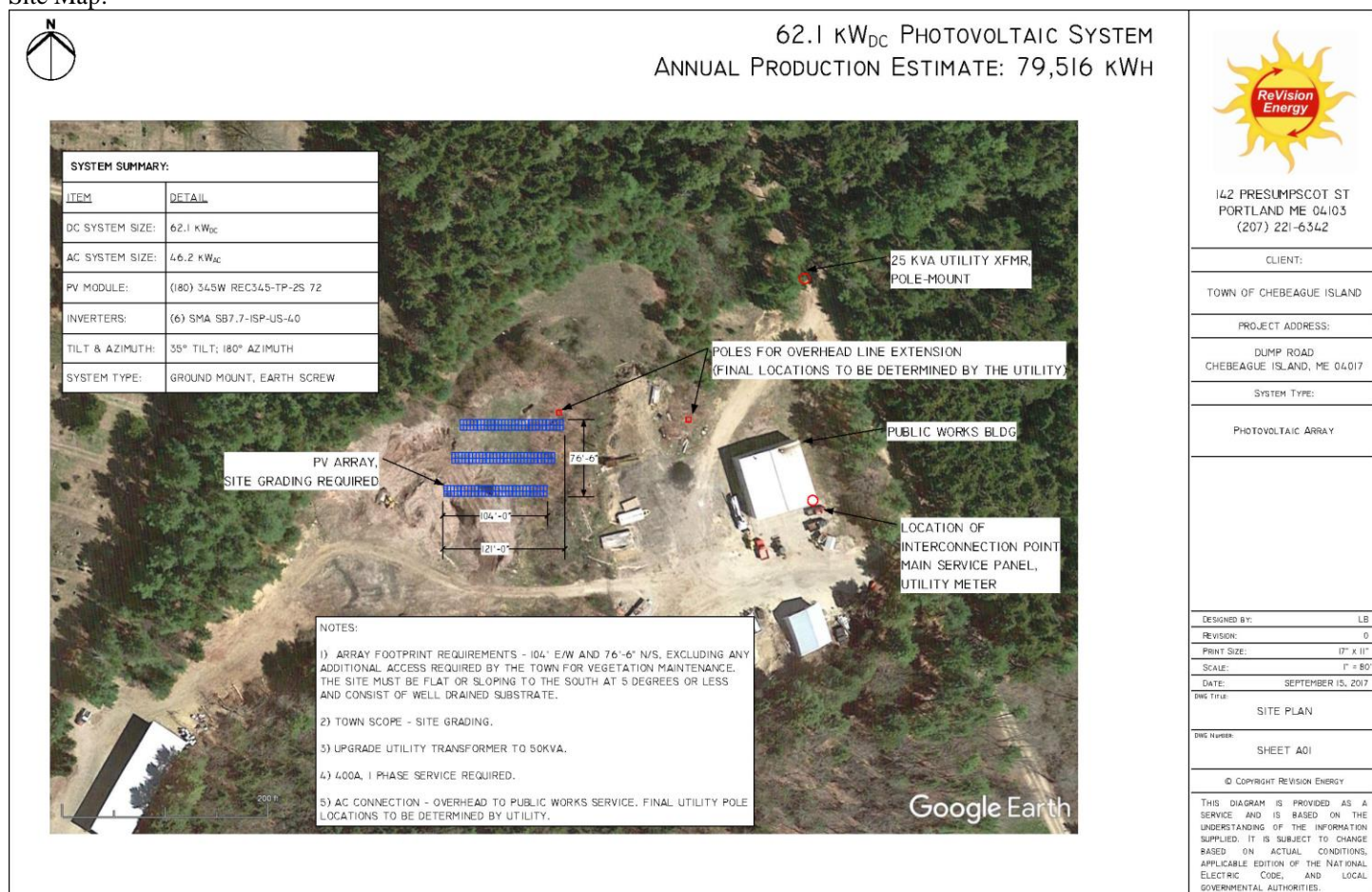

142 PRESUMPCOT ST
PORTLAND ME 04103
(207) 221-6342

CLIENT:	TOWN OF CHEBEAGUE ISLAND
PROJECT ADDRESS:	DUMP ROAD CHEBEAGUE ISLAND, ME 04017
SYSTEM TYPE:	PHOTOVOLTAIC ARRAY
DESIGNED BY:	LB
REVISION:	0
PRINT SIZE:	17" x 11"
SCALE:	1" = 80'
DATE:	SEPTEMBER 15, 2017
DWG TITLE:	SITE PLAN
DWG NUMBER:	SHEET A01
© COPYRIGHT REVISION ENERGY	
THIS DIAGRAM IS PROVIDED AS A SERVICE AND IS BASED ON THE UNDERSTANDING OF THE INFORMATION SUPPLIED. IT IS SUBJECT TO CHANGE BASED ON ACTUAL CONDITIONS, APPLICABLE EDITION OF THE NATIONAL ELECTRIC CODE, AND LOCAL GOVERNMENTAL AUTHORITIES.	

One-Line Drawing:

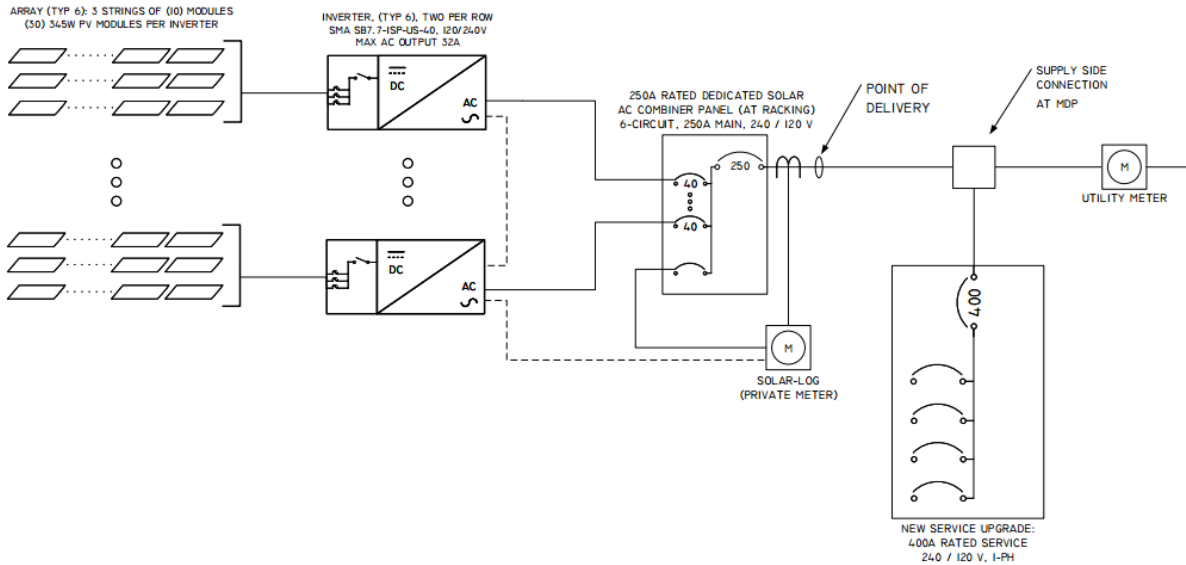

NOTES:
1) UPGRADE UTILITY TRANSFORMER TO 50KVA
2) UPGRADE MAIN SERVICE PANEL TO 400A



142 PRESUMPCOT ST
PORTLAND ME 04103
(207) 221-6342

CLIENT:

TOWN OF CHEBEAGUE ISLAND

PROJECT ADDRESS:

DUMP ROAD
CHEBEAGUE ISLAND, ME 04017

SYSTEM TYPE:

62.1 kWdc
PHOTOVOLTAIC ARRAY

DESIGNED BY: LB

REVISION: 0

PRINT SIZE: 17" x 11"

SCALE:

DATE: JUNE 27, 2017

DWG TITLE: ONE-LINE DIAGRAM

DWG NUMBER:

SHEET E01

© COPYRIGHT REVISION ENERGY

THIS DIAGRAM IS PROVIDED AS A SERVICE AND IS BASED ON THE UNDERSTANDING OF THE INFORMATION SUPPLIED. IT IS SUBJECT TO CHANGE BASED ON ACTUAL CONDITIONS, APPLICABLE EDITION OF THE NATIONAL ELECTRIC CODE, AND LOCAL GOVERNMENTAL AUTHORITIES.

Irradiance Zone and Shade Map: Omitted by agreement of the Parties, with the understanding that Purchaser's use and management of the Premises shall ensure that the system is not shaded.

End of Exhibit 2

Exhibit 3
Credit Information

Omitted by agreement of the Parties.

End of Exhibit 3

Exhibit 4
Solar Power Purchase Agreement
General Terms and Conditions

1. **Definitions and Interpretation.** Unless otherwise defined or required by the context in which any term appears: (a) the singular includes the plural and vice versa; (b) the words “herein,” “hereof” and “hereunder” refer to this Agreement as a whole and not to any particular section or subsection of this Agreement; (c) references to any agreement, document or instrument mean such agreement, document or instrument as amended, modified, supplemented or replaced from time to time; and (d) the words “include,” “includes” and “including” mean include, includes and including “without limitation.” The captions or headings in this Agreement are strictly for convenience and shall not be considered in interpreting this Agreement.
2. **Purchase and Sale of Electricity.** Purchaser shall purchase from Seller, and Seller shall sell to Purchaser, all of the electric energy generated by the System during the Initial Term and any Additional Term (as defined in **Exhibit 1**, and collectively the “Term”) and delivered to Purchaser at the delivery point identified on **Exhibit 2** (the “Delivery Point”). Seller shall report annually to the Purchaser the actual amount of electric energy generated by the System and the actual amount of electricity used by the Purchaser. Purchaser shall take title to the electric energy generated by the System at the Delivery Point, and risk of loss will pass from Seller to Purchaser at the Delivery Point. Purchaser may purchase electric energy for the Facility from other sources if the Purchaser's electric requirements at the Facility exceed the output of the System. Any purchase, sale and/or delivery of electric energy generated by the System prior to the Commercial Operation Date shall be treated as purchase, sale and/or delivery of limited amounts of test energy only and shall not indicate that the System has been put in commercial operation by the purchase, sale and/or delivery of such test energy.
3. **Purchase and Sale of Renewable Energy Credits.** If Purchaser elects the Renewable Energy Credit (REC) purchase option provided in **Exhibit 1**, Purchaser shall purchase from Seller, and Seller shall sell to Purchaser, all of the RECs generated by the System for the Contract Year and at the price per megawatt-hour specified for that year shown in **Exhibit 1**.
4. **Term and Termination.**
 - a. **Initial Term.** The initial term (“Initial Term”) of this Agreement shall commence on the Commercial Operation Date (as defined below) and continue for the length of time specified in **Exhibit 1**, unless earlier terminated as provided for in this Agreement. The “Commercial Operation Date” is the date Seller gives Purchaser written notice that the System is mechanically complete and capable of providing electric energy to the Delivery Point. Such notice shall be deemed effective unless Purchaser reasonably objects within five (5) days of the date of such notice. Upon Purchaser’s request, Seller will give Purchaser copies of certificates of completion or similar documentation from Seller’s contractor and the interconnection or similar agreement with the entity authorized and required under applicable law to provide electric distribution service to Purchaser at the Facility (the “Utility”), as set forth on **Exhibit 2**. This Agreement is effective as of the Effective Date and Purchaser’s failure to enable Seller to provide the electric energy by preventing it from installing the System or otherwise not performing shall not excuse Purchaser’s obligations to make payments that otherwise would have been due under this Agreement.
 - b. **Additional Terms.** Prior to the end of the Initial Term or of any applicable Additional Term, as defined below, if Purchaser has not exercised its option to purchase the System, either Party may give the other Party written notice of its desire to extend this Agreement on the terms and conditions set forth herein for the number and length of additional periods specified in **Exhibit 1** (each such additional period, an “Additional Term”). Such notice shall be given, if at all, not more than one hundred twenty (120) and not less than sixty (60) days before the last day of the Initial Term or the then current Additional Term, as applicable. The Party receiving the notice requesting an Additional Term shall respond positively or negatively to that request in writing within thirty (30) days after receipt of the request. Failure to respond within such thirty (30) day period shall be deemed a rejection of the offer for an Additional Term. If both Parties agree to an Additional Term, the Additional Term shall begin immediately upon the conclusion of the Initial Term or the then current term on the same terms and conditions as set forth in this Agreement. If the Party receiving the request for an Additional Term rejects or is deemed to reject the first Party’s offer, this Agreement shall terminate at the end of the Initial Term (if the same has not been extended) or the then current Additional Term.
5. **Billing and Payment.**
 - a. **Monthly Energy Charges.** Purchaser shall pay Seller monthly (or quarterly, if Seller elects quarterly invoicing under subsection (d) of this **Section 5**) for the electric energy generated by the System and delivered to the Delivery Point at the \$/kWh rate shown in **Exhibit 1** (the “Contract Price”). The periodic payment for such energy will be

equal to the applicable \$/kWh rate multiplied by the number of kWh of energy generated during each month of the applicable billing period, as measured by the System meter.

- b. **Monthly REC Charges.** If Purchaser elects the Renewable Energy Credit (REC) purchase option in Exhibit 1, for each year it exercises the option, Purchaser shall pay Seller monthly for all RECs generated by the System at the \$/MWh rate shown in Exhibit 1 (the “REC Price”). The monthly payment for such RECs will be equal to the applicable \$/MWh rate multiplied by the number of MWh of energy generated during the applicable month, as measured by the System meter.
- c. **Monthly Invoices.** Seller shall invoice Purchaser monthly in arrears, by mail or electronic mail. Such monthly invoices shall state (i) the amount of electric energy produced by the System and delivered to the Delivery Point, (ii) the energy and REC rates applicable to, and charges incurred by, Purchaser under this Agreement and (iii) the total amount due from Purchaser.
- d. **Seller’s Option for Quarterly Invoicing.** Seller, at Seller’s sole option, may elect to invoice Purchaser on a quarterly basis. If Seller exercises the option to invoice quarterly for one or more billing periods, it shall not prohibit Seller from invoicing Monthly thereafter. Seller shall provide Purchaser with at least thirty (30) days prior notice before changing the frequency of invoicing.
- e. RESERVED.
- f. **Payment Terms.** All amounts due under this Agreement shall be due and payable net thirty (30) days from receipt of invoice. Any undisputed portion of the invoice amount not paid within the thirty (30) day period shall accrue interest at the rate of one percent (1%) per month (but not to exceed the maximum rate permitted by law).

6. **Environmental Attributes and Environmental Incentives.**

Unless otherwise specified in Exhibit 1, Seller is the owner of all Environmental Attributes and Environmental Incentives and is entitled to the benefit of all Tax Credits, and Purchaser’s purchase of electricity under this Agreement does not include Environmental Attributes, Environmental Incentives or the right to Tax Credits or any other attributes of ownership and operation of the System, all of which shall be retained by Seller. Purchaser shall cooperate with Seller in obtaining, securing and transferring all Environmental Attributes and Environmental Incentives and the benefit of all Tax Credits, including by using the electric energy generated by the System in a manner necessary to qualify for such available Environmental Attributes, Environmental Incentives and Tax Credits. Purchaser shall not be obligated to incur any out-of-pocket costs or expenses in connection with such actions unless reimbursed by Seller. If any Environmental Incentives are paid directly to Purchaser, Purchaser shall pay such amounts over to Seller as soon as practicable.

Except for Contract Years in which Purchaser purchases RECs, Purchaser hereby acknowledges and consents to Seller’s exclusive right to (i) make any claim that electric energy provided to Purchaser was generated by the Project, (ii) all claims that Seller is responsible for the reductions in emissions of pollution and greenhouse gases resulting from the generation of such electric energy and (iii) all rights, title to and ownership of any and all RECs, credits, certificates, registrations, etc., evidencing or representing any of the foregoing attributes and to take any action necessary for Seller to claim, register, sell or otherwise dispose of such interests.

“**Environmental Attributes**” means any and all credits, benefits, emissions reductions, offsets, and allowances, howsoever entitled, attributable to the System, the production of electrical energy from the System and its displacement of conventional energy generation, including (a) any avoided emissions of pollutants to the air, soil or water such as sulfur oxides (SOx), nitrogen oxides (NOx), carbon monoxide (CO) and other pollutants; (b) any avoided emissions of carbon dioxide (CO₂), methane (CH₄), nitrous oxide, hydrofluorocarbons, perfluorocarbons, sulfur hexafluoride and other greenhouse gases (GHGs) that have been determined by the United Nations Intergovernmental Panel on Climate Change, or otherwise by law, to contribute to the actual or potential threat of altering the Earth’s climate by trapping heat in the atmosphere; and (c) the reporting rights related to these avoided emissions, such as Green Tag Reporting Rights and Renewable Energy Credits. Green Tag Reporting Rights are the right of a party to report the ownership of accumulated Green Tags in compliance with federal or state law, if applicable, and to a federal or state agency or any other party, and include Green Tag Reporting Rights accruing under Section 1605(b) of The Energy Policy Act of 1992 and any present or future federal, state, or local law, regulation or bill, and international or foreign emissions trading program. Environmental Attributes do not include Environmental Incentives and Tax Credits. Purchaser and Seller shall file all tax returns in a manner consistent with this Section 6. Without limiting the generality of the foregoing, Environmental Attributes include carbon trading credits, renewable energy credits or certificates, emissions reduction credits, emissions allowances, green tags tradable renewable credits and Green-e® products.

“**Environmental Incentives**” means any and all credits, rebates, subsidies, payments or other incentives that relate to self-generation of electricity, the use of technology incorporated into the System, environmental benefits of using the System, or other similar programs available from the Utility, any other regulated entity, the manufacturer of any part of the System or any Governmental Authority, except in no case related to the levying or assessment of property taxes.

“**Governmental Authority**” means any national, state or local government (whether domestic or foreign), any political subdivision thereof or any other governmental, quasi-governmental, judicial, public or statutory instrumentality, authority, body, agency, bureau or entity (including the Federal Energy Regulatory Commission, a state Public Utilities Commission or Independent System Operator), or any arbitrator with authority to bind a party at law.

“**Tax Credits**” means any and all (a) investment tax credits, (b) production tax credits and (c) similar tax credits or grants under federal, state or local law relating to the construction, ownership or production of energy from the System.

7. **Conditions to Obligations.**

a. **Conditions to Seller’s Obligations.** Seller’s obligations under this Agreement are conditioned on the completion of the following conditions to Seller’s reasonable satisfaction on or before the Condition Satisfaction Date:

- i. Completion of a physical inspection of the Facility and the property upon which the Facility is located (the “**Premises**”) including, if applicable, geotechnical work, and real estate due diligence to confirm the suitability of the Facility and the Premises for the System;
- ii. Approval of (A) this Agreement and (B) the Construction Agreement (if any) for the System by Seller’s Financing Parties. “**Construction Agreement**” as used in this subsection means an agreement between Seller and any contractor or subcontractor to install all or part of the System;
- iii. Confirmation that Seller will obtain all applicable Environmental Incentives and Tax Credits;
- iv. Receipt of all necessary zoning, land use and building permits; and
- v. Execution of all necessary agreements with the Utility for interconnection of the System to Facility electrical system and/or the Utility’s electric distribution system.

b. **Failure of Conditions.** If any of the conditions listed in subsection (a) are not satisfied by the Condition Satisfaction Date, the Parties will attempt in good faith to negotiate new dates for the satisfaction of the failed conditions. If the Parties are unable to negotiate new dates then Seller may terminate this Agreement upon ten (10) days written notice to Purchaser without liability for costs or damages or triggering a default under this Agreement.

c. **Commencement of Construction.** Seller’s obligation to commence construction and installation of the System is conditioned on Seller’s receipt of (A) proof of insurance for all insurance required to be maintained by Purchaser under this Agreement, (B) written confirmation from any person holding a mortgage, lien or other encumbrance over the Premises or the Facility, as applicable, that such person will recognize Seller’s rights under this Agreement for as long Seller is not in default hereunder and (C), a signed and notarized original copy of the license agreement suitable for recording, substantially in the form attached hereto as **Exhibit 6** (the “**License Agreement**”).

d. **Conditions to Purchaser’s Obligations.** Purchaser’s obligations under **Section 5.a** are conditioned on the occurrence of the Commercial Operation Date for the System by the Outside Commercial Operation Date.

8. **Seller’s Rights and Obligations.**

a. **Permits and Approvals.** Seller, with Purchaser’s reasonable cooperation, shall use commercially reasonable efforts to obtain, at its sole cost and expense:

- i. any zoning, land use and building permits required to construct, install and operate the System;
- ii. any agreements and approvals from the Utility necessary in order to interconnect the System to the Facility electrical system and/or the Utility’s electric distribution system; and
- iii. any agreements and approvals from the Utility or Public Utilities Commission necessary in order to net meter energy produced by the System among Purchaser’s Utility meters and/or accounts.

Purchaser shall cooperate with Seller's reasonable requests to assist Seller in obtaining such agreements, permits and approvals. Where required, Purchaser shall obtain all such agreements, permits and approvals in Purchaser's name to enable and benefit operation of the System, however, Seller shall pay or reimburse Purchaser for all fees required. Once all such permits and approvals are obtained, Seller agrees to promptly comply with all laws, ordinances, rules and regulations of governmental authorities (including, but not limited to, environmental and land use laws and ordinances) affecting the Premises, including but not limited to, installations, repairs, maintenance and alterations that are necessitated by any such laws, ordinances, rules and regulations.

- b. **Standard System Repair and Maintenance.** Seller shall construct and install the System at the Facility. During the Term, Seller will operate and perform all routine and emergency repairs to, and maintenance of, the System at its sole cost and expense, except for any repairs or maintenance resulting from Purchaser's negligence, willful misconduct or breach of this Agreement. Seller shall not be responsible for any work done by others on any part of the System unless Seller authorizes that work in advance in writing. Seller shall not be responsible for any loss, damage, cost or expense arising out of or resulting from improper environmental controls or improper operation or maintenance of the System by anyone other than Seller or Seller's contractors. If the System requires repairs for which Purchaser is responsible, Purchaser shall pay Seller for diagnosing and correcting the problem at Seller or Seller's contractors' then current standard rates. Seller shall provide Purchaser with reasonable notice prior to accessing the Facility to make standard repairs.
- c. **Non-Standard System Repair and Maintenance.** If Seller incurs incremental costs to maintain the System due to conditions at the Premises or Facility, or due to the inaccuracy of any information provided by Purchaser and relied upon by Seller, the Parties will negotiate such equitable adjustment in good faith. If an equitable adjustment cannot be negotiated and the current Agreement remains unchanged and in place, then Seller may terminate this Agreement without obligation to Purchaser.
- d. **Breakdown Notice.** Seller shall notify Purchaser within twenty-four (24) hours following Seller's discovery of (i) any material malfunction in the operation of the System or (ii) an interruption in the supply of electrical energy from the System. Purchaser and Seller shall each designate personnel and establish procedures such that each Party may provide notice of such conditions requiring Seller's repair or alteration at all times, twenty-four (24) hours per day, including weekends and holidays. Purchaser shall notify Seller immediately upon the discovery of an emergency condition affecting the System, provided that, notwithstanding anything to the contrary in this Agreement, Purchaser's failure to so notify Seller shall not impose any liability whatsoever on Purchaser. To the extent that Purchaser is required to purchase replacement electricity during any outage lasting for thirty (30) days or more, Seller shall reimburse Purchaser the difference, if any, between the cost of replacement electricity and the purchase price set forth in Exhibit 1.
- e. **Suspension.** Notwithstanding anything to the contrary herein, Seller shall be entitled to suspend delivery of electricity from the System to the Delivery Point for the purpose of maintaining and repairing the System and such suspension of service shall not constitute a breach of this Agreement; provided, that Seller shall use commercially reasonable efforts to minimize any interruption in service to the Purchaser.
- f. **Use of Contractors and Subcontractors.** Seller shall be permitted to use contractors and subcontractors to perform its obligations under this Agreement, provided however, that such contractors and subcontractors shall be duly licensed and shall provide any work in accordance with applicable industry standards. Notwithstanding the foregoing, Seller shall continue to be responsible for the quality of the work performed by its contractors and subcontractors.
- g. **Liens and Payment of Contractors and Suppliers.** Seller shall pay when due all valid charges from all contractors, subcontractors and suppliers supplying goods or services to Seller under this Agreement and shall keep the Facility free and clear of any liens related to such charges, except for those liens which Seller is permitted by law to place on the Facility following non-payment by Purchaser of amounts due under this Agreement. Seller shall indemnify Purchaser for all claims, losses, damages, liabilities and expenses, including attorney's fees, resulting from any liens filed against the Facility or the Premises in connection with such charges; provided, however, that Seller shall have the right to contest any such lien, so long as it provides a statutory bond or other reasonable assurances of payment that either remove such lien from title to the Facility and the Premises or that assure that any adverse judgment with respect to such lien will be paid without affecting title to the Facility and the Premises. Seller shall remove any lien or encumbrance filed by any third party in the Cumberland County Registry of Deeds which affects title to the Premises, within forty-five (45) days of notification by Purchaser. Seller's obligations under this paragraph shall survive termination of this Agreement.
- h. **No Warranty.** NO WARRANTY OR REMEDY, WHETHER STATUTORY, WRITTEN, ORAL, EXPRESS OR IMPLIED, INCLUDING WITHOUT LIMITATION WARRANTIES OF MERCHANTABILITY AND FITNESS

FOR A PARTICULAR PURPOSE, OR WARRANTIES ARISING FROM COURSE OF DEALING OR USAGE OF TRADE SHALL APPLY. The remedies set forth in this Agreement shall be Purchaser's sole and exclusive remedies for any claim or liability arising out of or in connection with this Agreement, whether arising in contract, tort (including negligence), strict liability or otherwise. The Manufacturers' Warranties described in Exhibit 2 to this Agreement (25-year module performance warranty and 10-year inverter performance warranty) and the Warranties described in Section 15(c) are excluded from the terms of this subparagraph 8(h).

9. **Purchaser's Rights and Obligations.**

- a. **License to the Premises; Facility Access Rights.** Subject to the terms and conditions of the License Agreement attached hereto as Exhibit 6, Purchaser grants to Seller and to Seller's agents, employees, contractors and assignees a revocable non-exclusive license running with the Premises (the "**License**") for access to, on, over, under and across only that portion of the Facility and Premises, as generally depicted in the Site Plan in Exhibit 2, Attachment A, as necessary for the sole purpose of (i) installing, constructing, operating, owning, maintaining, accessing, removing and replacing the System; (ii) performing all of Seller's obligations and enforcing all of Seller's rights set forth in this Agreement; and (iii) installing, using and maintaining electric lines and equipment, including inverters and meters necessary to interconnect the System to Purchaser's electric system at the Facility, to the Utility's electric distribution system, if any, or for any other purpose that may from time to time be useful or necessary in connection with the construction, installation, operation, maintenance or repair of the System. Seller shall notify Purchaser prior to entering the Facility except in situations where there is imminent risk of injury or damage to persons or property. The term of the License shall continue until the date that is one hundred and twenty (120) days following the date of expiration or termination of this Agreement (the "**License Term**"). During the License Term, Purchaser shall ensure that Seller's rights under the License and Seller's access to the Premises and the Facility are preserved and protected. Purchaser shall not interfere with or willingly permit any third parties to interfere with such rights or access. The grant of the License shall survive termination of this Agreement by up to 120 days if necessary to remove the system pursuant to Section 12 of this agreement. At request of Seller, Purchaser shall execute a Memorandum of License, which shall be in form and substance set forth as **Exhibit 5**, or other form agreed to by the parties. Seller may, at its sole cost and expense, record such Memorandum of License with the appropriate land registry or recorder's office.
- b. **OSHA Compliance.** Both parties shall ensure that all Occupational Safety and Health Act (OSHA) requirements and other similar applicable safety laws or codes are adhered to in their performance under this Agreement.
- c. **Maintenance of Facility and Premises.** Purchaser shall, at its sole cost and expense, maintain the Facility and Premises in good condition and repair. Purchaser will ensure that the Facility remains interconnected to the Utility's electric distribution system at all times and will not cause cessation of electric service to the Facility from the Utility. Purchaser is fully responsible for the maintenance and repair of the Facility's electrical system and of all of Purchaser's equipment that utilizes the System's outputs. Purchaser shall properly maintain in full working order all of Purchaser's electric supply or generation equipment that Purchaser may shut down while utilizing the System. Purchaser shall promptly notify Seller of any matters of which it is aware pertaining to any damage to or loss of use of the System or that could reasonably be expected to adversely affect the System.
- d. **No Alteration of Facility.** Purchaser shall not make any alterations or repairs to the Facility and Premises which could adversely affect the operation and maintenance of the System without Seller's prior written consent. If Purchaser wishes to make such alterations or repairs, Purchaser shall give prior written notice to Seller, setting forth the work to be undertaken (except for emergency repairs, for which notice may be given by telephone), and give Seller the opportunity to advise Purchaser in making such alterations or repairs in a manner that avoids damage to the System, but, notwithstanding any such advice, Purchaser shall be responsible for all damage to the System caused by Purchaser or its contractors. To the extent that temporary disconnection or removal of the System is necessary to perform such alterations or repairs, such work and any replacement of the System after completion of Purchaser's alterations and repairs, shall be done by Seller or its contractors at Purchaser's cost. In addition, Purchaser shall pay Seller an amount equal to the sum of (i) payments that Purchaser would have made to Seller hereunder for electric energy that would have been produced by the System during such disconnection or removal; (ii) revenues that Seller would have received with respect to the System under the any rebate program and any other assistance program with respect to electric energy that would have been produced during such disconnection or removal; (iii) revenues from Environmental Attributes that Seller would have received with respect to electric energy that would have been produced by the System during such disconnection or removal; and (iv) Tax Credits that Seller (or, if Seller is a pass-through entity for tax purposes, Seller's owners) would have received with respect to electric energy that would have been produced by the System during such disconnection or removal. Determination of the amount of energy that would have been produced during any disconnection or removal shall be in accordance with the procedures in **Section 11.b**. All of Purchaser's alterations and repairs will be done in a good and workmanlike manner and in compliance with all applicable laws, codes and permits.

- e. **Outages.** Notwithstanding anything to the contrary in Section 9(d) or elsewhere in this Agreement, Purchaser shall be permitted to be off line for a total of forty-eight (48) daylight hours (each, a “**Scheduled Outage**”) per calendar year during the Term, during which hours Purchaser shall not be obligated to accept or pay for electricity from the System; provided, however, that Purchaser must notify Seller in writing of each such Scheduled Outage at least forty-eight (48) hours in advance of the commencement of a Scheduled Outage. In the event that Scheduled Outages exceed a total of forty-eight (48) daylight hours per calendar year or there are unscheduled outages, in each case for a reason other than a Force Majeure event, Purchaser shall pay Seller an amount equal to the sum of (i) payments that Purchaser would have made to Seller hereunder for electric energy that would have been produced by the System during the outage; (ii) revenues that Seller would have received with respect to the System under any rebate program and any other assistance program with respect to electric energy that would have been produced during the outage; (iii) revenues from Environmental Attributes that Seller would have received with respect to electric energy that would have been produced by the System during the outage; and (iv) Tax Credits that Seller (or, if Seller is a pass-through entity for tax purposes, Seller’s owners) would have received with respect to electric energy that would have been produced by the System during the outage. Determination of the amount of energy that would have been produced during the removal or disconnection shall be in accordance with the procedures in Section 11.b.
- f. **Liens.** Purchaser shall not directly or indirectly cause, create, incur, assume or allow to exist any mortgage, pledge, lien, charge, security interest, encumbrance or other claim of any nature on or with respect to the System or any interest therein. Purchaser shall immediately notify Seller in writing of the existence of any such mortgage, pledge, lien, charge, security interest, encumbrance or other claim, shall promptly cause the same to be discharged and released of record without cost to Seller, and shall indemnify Seller against all costs and expenses (including reasonable attorneys’ fees) incurred in discharging and releasing any such mortgage, pledge, lien, charge, security interest, encumbrance or other claim. Notwithstanding anything else herein to the contrary, pursuant to Section 20.a, Seller may grant a lien on the System and may assign, mortgage, pledge or otherwise collaterally assign its interests in this Agreement and the System to any Financing Party.
- g. **Security.** Purchaser shall be responsible for using commercially reasonable efforts to maintain the physical security of the Facility and the System against known risks and risks that should have been known by Purchaser. Purchaser will not conduct activities on, in or about the Premises or the Facility that have a reasonable likelihood of causing damage, impairment or otherwise adversely affecting the System.
- h. **Insolation.** Purchaser understands that unobstructed access to sunlight (“**Insolation**”) is essential to Seller’s performance of its obligations and a material term of this Agreement. Purchaser shall not in any way cause and, where possible, shall not in any way permit any interference with the System’s Insolation. If Purchaser becomes aware of any activity or condition that could diminish the Insolation of the System, Purchaser shall notify Seller immediately and shall cooperate with Seller in preserving the System’s existing Insolation levels. The Parties agree that reducing Insolation would irreparably injure Seller, that such injury may not be adequately compensated by an award of money damages, and that Seller is entitled to seek specific enforcement of this Section 9.h against Purchaser. If Purchaser allows vegetation to shade the System or causes any activity or condition that diminishes Insolation levels specified in Exhibit 2 Attachment A so as to cause energy generation of the System to fall more than 15 % below projections in Exhibit 1, Purchaser and Seller agree that until the activity ceases or conditions are returned to Insolation levels specified in Exhibit 2 Attachment A, Seller may bill for energy based on the amount of energy that would have been produced without loss of Insolation in accordance with the procedures in Section 11.b.

10. **Change in Law.**

“**Change in Law**” means (i) the enactment, adoption, promulgation, modification or repeal after the Effective Date of any applicable law or regulation; (ii) the imposition of any material conditions on the issuance or renewal of any applicable permit after the Effective Date of this Agreement (notwithstanding the general requirements contained in any applicable Permit at the time of application or issue to comply with future laws, ordinances, codes, rules, regulations or similar legislation), or (iii) a change in any utility rate schedule or tariff approved by any Governmental Authority which in the case of any of (i), (ii) or (iii), establishes requirements affecting owning, supplying, constructing, installing, operating or maintaining the System, or other performance of the Seller’s obligations hereunder and which has a material adverse effect on the cost to Seller of performing such obligations; provided, that a change in federal, state, county or any other tax law after the Effective Date of this Agreement shall not be a Change in Law pursuant to this Agreement.

If any Change in Law occurs that has a material adverse effect on the cost to Seller of performing its obligations under this Agreement, then the Parties shall, within thirty (30) days following receipt by Purchaser from Seller of notice of such Change in Law, meet and attempt in good faith to negotiate amendments to this Agreement as are reasonably necessary to preserve the economic value of this Agreement to both Parties. If the Parties are unable to agree upon such amendments within such thirty

(30) day period, then Seller shall have the right to terminate this Agreement without further liability to either Party except with respect to payment of amounts accrued prior to termination.

11. Relocation of System.

- a. System Relocation. If Purchaser ceases to conduct business operations at the Facility, or otherwise vacates or re-purposes Premises upon which the Facility is located, in the discretion of the Purchaser, prior to the expiration of the Term, Purchaser shall have the option to provide Seller with a mutually agreeable substitute premises located within the same utility district as the terminated System or in a location with similar utility rates and Insolation. Purchaser shall provide written notice at least sixty (60) days but not more than one hundred eighty (180) days prior to the date that it wants to make this substitution. In connection with such substitution, Purchaser shall execute an amended agreement that shall have all of the same terms as this Agreement except for the (i) Effective Date; (ii) License, which will be amended to grant rights in the real property where the System is relocated to; and (iii) Term, which will be equal to the remainder of the Term of this Agreement calculated starting at the shutdown of the System pursuant to such relocation, and shall toll until the relocated System achieves commercial operation of such new location. Such amended agreement shall be deemed to be a continuation of this Agreement without termination. In addition, Purchaser shall be obligated to provide a new executed and notarized license agreement covering the substitute premises in form and content substantially similar to the License Agreement. Purchaser shall also provide any new consents, estoppels, or acknowledgments reasonably required by Financing Parties in connection with the substitute premises.
- b. Costs of Relocation. Purchaser shall pay all costs associated with relocation of the System, including all costs and expenses incurred by or on behalf of Seller in connection with removal of the System from the Facility and installation and testing of the System at the substitute facility and all applicable interconnection fees and expenses at the substitute facility, as well as costs of new title search and other out-of-pocket expenses connected to preserving and re-filing the security interests of Seller's Financing Parties in the System. In addition, Purchaser shall pay Seller an amount equal to the sum of (i) payments that Purchaser would have made to Seller hereunder for electric energy that would have been produced by the System during the relocation; (ii) revenues that Seller would have received with respect to the System under the any rebate program and any other assistance program with respect to electric energy that would have been produced during the relocation; (iii) revenues from Environmental Attributes that Seller would have received with respect to electric energy that would have been produced by the System during the relocation; and (iv) Tax Credits that Seller (or, if Seller is a pass-through entity for tax purposes, Seller's owners) would have received with respect to electric energy that would have been produced by the System during the relocation. Determination of the amount of energy that would have been produced during the relocation shall be based, during the first Contract Year, on the estimated levels of production and, after the first Contract Year, based on actual operation of the System in the same period in the previous Contract Year, unless Seller and Purchaser mutually agree to an alternative methodology. "Contract Year" means the twelve-month period beginning at 12:00 AM on the Commercial Operation Date or on any anniversary of the Commercial Operation Date and ending at 11:59 PM on the day immediately preceding the next anniversary of the Commercial Operation Date, provided that the first Contract Year shall begin on the Commercial Operation Date.
- c. Adjustment for Insolation; Termination. Seller shall remove the System from the vacated Facility prior to the termination of Purchaser's ownership, lease or other rights to use such Facility. Seller will not be required to restore the Facility to its prior condition but shall promptly pay Purchaser for any damage caused by Seller during removal of the System, but not for normal wear and tear. If the substitute facility has inferior Insolation as compared to the original Facility, Seller shall have the right to make an adjustment to **Exhibit 1** such that Purchaser's payments to Seller are the same as if the System were located at the original Facility, increased to the extent necessary to compensate Seller for reduced revenues from Environmental Attributes and reduced Tax Credits that Seller (or, if Seller is a pass-through entity for tax purposes, Seller's owners) receive as a result of the relocation. If Purchaser is unable to provide such substitute facility and to relocate the System as provided, any early termination will be treated as a default by Purchaser.

12. Removal of System at Expiration.

Upon the expiration or earlier termination of this Agreement (provided Purchaser does not exercise its purchase option), Seller shall, at its expense, remove all of its tangible property comprising the System from the Facility on a mutually convenient date, but in no event later than one-hundred and twenty (120) days after the expiration of the Term. Excluding ordinary wear and tear, the Facility and Premises shall be returned to its original condition. Seller shall not be obligated to remove any below grade structures, including foundations and conduits, or any roads. Seller shall leave the Facility and premises in neat and clean order. If Seller fails to remove or commence substantial efforts to remove the System by such agreed upon date, Purchaser shall have the right, at its option, to remove the System to a public warehouse and restore the Facility and Premises to its

original condition (other than ordinary wear and tear) at Seller's cost. Purchaser shall provide sufficient space for the temporary storage and staging of tools, materials and equipment and for the parking of construction crew vehicles and temporary construction trailers and facilities reasonably necessary during System removal.

13. **Measurement.** Seller shall install one or more meter(s), as Seller deems appropriate, at or immediately before the Delivery Point to measure the output of the System. Such meter shall meet the general commercial standards of the solar photovoltaic industry or the required standard of the Utility. Seller shall maintain the meter(s) in accordance with industry standards. Seller may provide a remote accessible data logging and reporting system during the Term to enable Seller to remotely record the amount of electric energy generated by the System. During such time the monitoring and/or reporting system ceases to function, but not longer than 180 days, Seller may reasonably estimate the amount of electric energy that was generated and invoice Purchaser for such amount in accordance with Section 5. Within 180 days of invoicing estimated charges, the estimated production shall be compared to actual production based on a physical reading of the on-site meter and Seller shall issue an invoice or credit, as the case may be, to correct overages or underages that occurred during the period invoices were based on estimated production.

14. **Default, Remedies and Damages.**

a. **Default.** Any Party that fails to perform its responsibilities as listed below or experiences any of the circumstances listed below shall be deemed to be the “**Defaulting Party**”, the other Party shall be deemed to be the “**Non-Defaulting Party**”, and each event of default shall be a “**Default Event**”:

- i. failure of a Party to pay any amount due and payable under this Agreement, other than an amount that is subject to a good faith dispute, within thirty (30) days following receipt of written notice from the Non-Defaulting Party of such failure to pay (“**Payment Default**”);
- ii. failure of a Party to substantially perform any other material obligation under this Agreement within thirty (30) days following receipt of written notice from the Non-Defaulting Party demanding such cure; provided, that such thirty (30) day cure period shall be extended (but not beyond ninety (90) days) if and to the extent reasonably necessary to cure the Default Event, if (A) the Defaulting Party initiates such cure within the thirty (30) day period and continues such cure to completion and (B) there is no material adverse effect on the Non-Defaulting Party resulting from the failure to cure the Default Event;
- iii. if any representation or warranty of a Party proves at any time to have been incorrect in any material respect when made and is material to the transactions contemplated hereby, if the effect of such incorrectness is not cured within thirty (30) days following receipt of written notice from the Non-Defaulting Party demanding such cure;
- iv. Purchaser loses its rights to occupy and enjoy the Premises unless such loss of rights results from Seller's default under this Agreement, a Force Majeure event, or from the condemnation, eminent domain or other governmental taking of the Premises;
- v. Purchaser revokes the license granted to Seller pursuant to this Agreement for a reason other than the expiration or earlier termination of this Agreement;
- vi. a Party becomes insolvent or is a party to a bankruptcy, reorganization, insolvency, liquidation, receivership, dissolution, winding-up or relief of debtors, or any general assignment for the benefit of creditors or other similar arrangement or any event occurs or proceedings are taken in any jurisdiction with respect to the Party which has a similar effect, and, if any such bankruptcy or other proceedings were initiated by a third party, if such proceedings have not been dismissed within sixty (60) days following receipt of a written notice from the Non-Defaulting Party demanding such cure; or
- vii. Purchaser prevents Seller from installing the System or otherwise failing to perform in a way that prevents the delivery of electric energy from the System. Such Default Event shall not excuse Purchaser's obligations to make payments that otherwise would have been due under this Agreement.
- viii. **Right to Cure.** Both Parties shall have a right to cure any default as set forth in this subsection.

- (1) **Cure Period.** Neither Party may exercise any right to terminate or suspend this Agreement unless it shall have given the defaulting Party prior written notice of its intent to terminate or suspend this Agreement, as required by this Agreement, specifying the condition giving rise to such right, and the defaulting Party shall not have caused to be cured the condition giving rise to the right of

termination or suspension within thirty (30) days after such notice or (if longer) the periods provided for in this Agreement; provided that if such default reasonably cannot be cured by the defaulting Party within such period and the defaulting Party commences and continuously pursues cure of such default within such period, such period for cure will be extended for a reasonable period of time under the circumstances, such period not to exceed an additional ninety (90) days. The Parties' respective obligations will otherwise remain in effect during any cure period.

- (2) Continuation of Agreement. If the defaulting Party, within the time periods described in Section 20(c)(i) above, cures all defaults under this Agreement in the manner required by this Agreement, then such Party shall no longer be in default under this Agreement, and this Agreement shall continue in full force and effect.

b. Remedies.

- i. Remedies for Payment Default. If a Payment Default occurs, the Non-Defaulting Party may suspend performance of its obligations under this Agreement. Further, the Non-Defaulting Party may (A) at any time during the continuation of the Default Event, terminate this Agreement upon five (5) days prior written notice to the Defaulting Party, and (B) pursue any remedy under this Agreement, at law or in equity, including an action for damages.
- ii. Remedies for Other Defaults. On the occurrence of a Default Event other than a Payment Default, the Non-Defaulting Party may (A) at any time during the continuation of the Default Event, terminate this Agreement or suspend its performance of its obligations under this Agreement, upon five (5) days prior written notice to the Defaulting Party, and (B) pursue any remedy under this Agreement, at law or in equity, including an action for damages. Nothing herein shall limit either Party's right to collect damages upon the occurrence of a breach or a default by the other Party that does not become a Default Event. If Purchaser terminates this contract without cause prior to commencement of System installation, a five thousand dollar (\$5,000) design cancellation fee shall also apply in addition to any other remedy available to Seller.
- iii. Damages Upon Termination by Default. Upon a termination of this Agreement by the Non-Defaulting Party as a result of a Default Event by the Defaulting Party, the Defaulting Party shall pay a Termination Payment to the Non-Defaulting Party determined as follows (the "**Termination Payment**"):
- A. Purchaser. If Purchaser is the Defaulting Party and Seller terminates this Agreement, the Termination Payment to Seller shall be equal to the sum of (1) reasonable compensation, on a net after tax basis assuming a tax rate of thirty-five percent (35%), for the loss or recapture of (a) the investment tax credit equal to thirty percent (30%) of the System value; (b) MACRS accelerated depreciation equal to eighty five percent (85%) of the System value, (c) loss of any Environmental Attributes or Environmental Incentives that accrue or are otherwise assigned to Seller pursuant to the terms of this Agreement (Seller shall furnish Purchaser with a detailed calculation of such compensation if such a claim is made), (d) other financing and associated costs not included in (a), (b) and (c), (2) the net present value (using a discount rate of four and sixty two hundredths percent (4.62%)) of the projected payments over the Term post-termination, had the Term remained effective for the full Initial Term, (3) removal costs as provided in Section 14.b.iii.C and (4) any and all other amounts previously accrued under this Agreement and then owed by Purchaser to Seller. The Parties agree that actual damages to Seller in the event this Agreement terminates prior to the expiration of the Term as the result of a Default Event by Purchaser would be difficult to ascertain, and the applicable Termination Payment is a reasonable approximation of the damages suffered by Seller as a result of early termination of this Agreement. The Termination Payment shall not be less than zero.
- B. Seller. If Seller is the Defaulting Party and Purchaser terminates this Agreement, the Termination Payment to Purchaser shall be equal to the sum of (1) all costs reasonably incurred by Purchaser in re-converting its electric supply to service from the Utility (but not including any differences in the price of delivered energy); (2) any removal costs incurred by Purchaser to return the Premises to its prior condition pursuant to Section 12; (3) all costs incurred by Purchaser in installing the Facility and connecting it to the Utility; and (4) any and all other amounts previously accrued under this Agreement and then owed by Seller to Purchaser. The Termination Payment shall not be less than zero.

- C. Obligations Following Termination. If a Non-Defaulting Party terminates this Agreement pursuant to this Section 14.b, then following such termination, Seller shall, at the sole cost and expense of the Defaulting Party, remove the System consistent with Section 12. The Non-Defaulting Party shall take all commercially reasonable efforts to mitigate its damages as the result of a Default Event.

15. **Representations, Warranties and Covenants.**

- a. **General Representations and Warranties.** Each Party represents and warrants to the other the following as of the Effective Date:
- i. Such Party is duly organized, validly existing and in good standing under the laws of the jurisdiction of its formation; the execution, delivery and performance by such Party of this Agreement have been duly authorized by all necessary municipal, corporate, partnership or limited liability company action, as applicable, and do not and shall not violate any law; and this Agreement is valid obligation of such Party, enforceable against such Party in accordance with its terms (except as may be limited by applicable bankruptcy, insolvency, reorganization, moratorium and other similar laws now or hereafter in effect relating to creditors' rights generally).
 - ii. Such Party has obtained all licenses, authorizations, consents and approvals required by any Governmental Authority or other third party and necessary for such Party to own its assets, carry on its business and to execute and deliver this Agreement; and such Party is in compliance with all laws that relate to this Agreement in all material respects.
- b. **Purchaser's Representations, Warranties and Covenants.** Purchaser represents and warrants to Seller the following as of the Effective Date and covenants that throughout the Term:
- i. License. Purchaser has title to or a leasehold or other property interest in the Premises. Purchaser has the full right, power and authority to grant the License contained in Section 9.a. Such grant of the License does not violate any law, ordinance, rule or other governmental restriction applicable to Purchaser or the Facility and is not inconsistent with and will not result in a breach or default under any agreement by which Purchaser is bound or that affects the Facility.
 - ii. Other Agreements. Neither the execution and delivery of this Agreement by Purchaser nor the performance by Purchaser of any of its obligations under this Agreement conflicts with or will result in a breach or default under any agreement or obligation to which Purchaser is a party or by which Purchaser or the Facility is bound.
 - iii. Accuracy of Information. All information provided by Purchaser to Seller, as it pertains to the Facility's physical configuration, Purchaser's planned use of the Facility, and Purchaser's estimated electricity requirements, is accurate in all material respects.
 - iv. Purchaser Status. Purchaser is not a public utility or a public utility holding company and is not subject to regulation as a public utility or a public utility holding company.
 - v. Hazardous Substances. There are no Hazardous Substances at, on, above, below or near the Premises.
 - vi. No Pool Use. No electricity generated by the System will be used to heat a swimming pool.
- c. **Seller's Representations, Warranties and Covenants.** Notwithstanding any other provisions set forth in this Agreement, Seller warrants that its performance and provision of services, and the performance and provision of its subcontractors and suppliers, under the terms of this Agreement will not infringe upon or violate any trademarks, patents, copyrights, trade secrets or other third party property (whether intellectual or otherwise) rights. Seller hereby agrees to indemnify and save the Purchaser, its affiliates, employees, directors, officers, agents, and contractors, harmless from and against, and defend such parties from, all liabilities, claims, costs and damages, including, but not limited to, reasonable attorneys' fees, arising out of any violation of the warranties provided in this paragraph, or otherwise, arising out of any assertion that provision or performance of any of the services, or the use of any of the services, constitutes an infringement upon or violates any patent, trademark, copyright, trade secret, or other intellectual property right. If any material, equipment, document, process, or apparatus provided by Seller, or if any of the services, or the use of any of the same, is held or determined to constitute an infringement upon or violation of any patent, trademark, copyright, trade secret, or other intellectual property right, or the use of any of the same is

enjoyed, Seller shall, within a reasonable time, secure for the Purchaser, at Seller's own expense, the right to continue to use such material, equipment, document, process, apparatus, and services by either obtaining the suspension or termination of any injunction, procuring for the Purchaser a license or other right to use the same, or obtaining the right in some other manner. In the alternative, and solely at the Purchaser's election, Seller shall, at Seller's expense and without injury or damage to any other property of the Purchaser: (i) replace such material, equipment, document, process, apparatus, and services with non-infringing items of the same quality and function; or (ii) modify such items so that they become non-infringing but perform the same functions and have the same quality as they had prior to such modification.

16. System and Facility Damage and Insurance.

a. System and Facility Damage.

- i. Seller's Obligations. If the **System** is damaged or destroyed other than by Purchaser's gross negligence or willful misconduct, Seller shall promptly repair and restore the System to its pre-existing condition; provided, however, that if more than fifty percent (50%) of the System is destroyed during the last five (5) years of the Initial Term or during any Additional Term, Seller shall not be required to restore the System, but may instead terminate this Agreement, unless Purchaser agrees (A) to pay for the cost of such restoration of the System or (B) to purchase the System "AS-IS" at the greater of (1) the Fair Market Value of the System and (2) the sum of the amounts described in Section 14.b.iii.A(1) and Section 14.b.iii.A(3). In each case (A) and (B) shall be reduced by the amount of any insurance proceeds available to Seller.
- ii. Purchaser's Obligations. If the **Facility** is damaged or destroyed by casualty of any kind or any other occurrence other than Seller's gross negligence or willful misconduct, such that the operation of the System and/or Purchaser's ability to accept the electric energy produced by the System are materially impaired or prevented, Purchaser shall promptly repair and restore the Facility to its pre-existing condition; provided, however, that if more than 50% of the Facility is destroyed during the last five years of the Initial Term or during any Additional Term, Purchaser may elect either (A) to restore the Facility or (B) to pay the Termination Payment and all other costs previously accrued but unpaid under this Agreement and thereupon terminate this Agreement.

b. Insurance Coverage. At all times during the Term, Seller and Purchaser shall maintain the following insurance:

- i. Seller's Insurance. Prior to execution of this Agreement, Seller shall procure and maintain (A) property insurance on the System for the replacement cost thereof, (B) commercial general liability insurance with coverage of at least \$1,000,000 per occurrence and \$2,000,000 annual aggregate, (C) employer's liability insurance with coverage of at least \$1,000,000 and (D) workers' compensation insurance as required by law. With respect to the property and commercial general liability insurance, Seller shall name Purchaser as an additional insured for coverage only in those areas where government immunity has been expressly waived by 14 M.R.S.A. § 8104-A, as limited by § 8104-B, and § 8111. This provision shall not be deemed a waiver of any defenses, immunities or limitations of liability or damages available under the Maine Tort Claims Act, other Maine statutory law, judicial precedent or common law. All such policies of insurance shall be primary to any policies of insurance of the Purchaser.
- ii. Purchaser's Insurance. Purchaser shall maintain commercial general liability insurance with coverage of at least the amount of Four Hundred Thousand Dollars (\$400,000) per occurrence for causes of action pursuant to the Maine Tort Claims Act, and will be increased from time to time, if required to meet the maximum coverage provisions of the Maine Tort Claims Act, as it may be amended. The Purchaser expressly reserves all immunity and discretionary rights, defenses and protections as provided by Maine law, including but not limited to the Maine Tort Claims Act.

c. Policy Provisions. All insurance policies provided hereunder shall (i) contain a provision whereby the insurer agrees to give the party not providing the insurance (A) not less than ten (10) days written notice before the insurance is cancelled, or terminated as a result of non-payment of premiums, or (B) not less than thirty (30) days written notice before the insurance is otherwise cancelled or terminated, (ii) be written on an occurrence basis, and (iii) be maintained with companies either rated no less than A-VII as to Policy Holder's Rating in the current edition of A.M. Best's Insurance Guide or otherwise reasonably acceptable to the other party.

d. Certificates. Upon the other Party's request each Party shall deliver the other Party certificates of insurance evidencing the above required coverage. A Party's receipt, review or acceptance of such certificate shall in no way limit or relieve the other Party of the duties and responsibilities to maintain insurance as set forth in this Agreement.

- e. **Deductibles.** Unless and to the extent that a claim is covered by an indemnity set forth in this Agreement, each Party shall be responsible for the payment of its own deductibles.

17. **Ownership; Option to Purchase.**

- a. **Ownership of System.** Throughout the Term (except as otherwise permitted in Section 20), Seller shall be the legal and beneficial owner of the System at all times, including all Environmental Attributes (unless otherwise specified on Exhibit 1), and the System shall remain the personal property of Seller and shall not attach to or be deemed a part of, or fixture to, the Facility or the Premises. Each of the Seller and Purchaser agree that the Seller (or the designated assignee of Seller permitted under Section 20) is the tax owner of the System and all tax filings and reports will be filed in a manner consistent with this Agreement. The System shall at all times retain the legal status of personal property as defined under Article 9 of the Uniform Commercial Code. Purchaser covenants that it will use commercially reasonable efforts to place all parties having an interest in or a mortgage, pledge, lien, charge, security interest, encumbrance or other claim of any nature on the Facility or the Premises on notice of the ownership of the System and the legal status or classification of the System as personal property. If there is any mortgage or fixture filing against the Premises which could reasonably be construed as prospectively attaching to the System as a fixture of the Premises, Purchaser shall provide a disclaimer or release from such lienholder. If Purchaser is the fee owner of the Premises, Purchaser consents to the filing of a disclaimer of the System as a fixture of the Premises in the office where real estate records are customarily filed in the jurisdiction where the Facility is located.
- b. **Option to Purchase.** Beginning on the sixth (6th) anniversary of the Commercial Operation Date (i.e., beginning in the seventh Contract Year), provided Purchaser is not in default under this Agreement, Purchaser shall annually have the option to purchase the System from Seller at a price equal to the Fair Market Value of the System at such anniversary date, plus, if applicable, a sum equal to the repayment or recapture of Applicable Solar Program or other governmental payments occasioned by the exercise of such option. Purchaser must provide a notification to Seller of its intent to purchase at least ninety (90) days and not more than one hundred eighty (180) days prior to the end of the applicable Contract Year or the Initial Term or Additional Term, as applicable, and the purchase shall be complete prior to the end of the applicable Contract Year or the Initial Term or Additional Term, as applicable. Any such purchase shall be on an as-is, where-is basis, and Seller shall not provide any warranty or other guarantee regarding the performance of the System; provided, however, that (i) the Warranties in Section 15.c are excluded from the terms of this subparagraph 17.b and, therefore, shall survive any purchase of the System by Purchaser; and (ii) Seller shall assign to Purchaser any Manufacturers Warranties that are in effect as of the purchase, and which are assignable pursuant to their terms. Upon purchase, Seller shall provide all maintenance and operational records to Purchaser.
- c. **Determination of Fair Market Value.** “Fair Market Value” means, in Seller’s reasonable determination, the greater of: (i) the amount that would be paid in an arm’s length, free market transaction, for cash, between an informed, willing seller and an informed willing buyer, neither of whom is under compulsion to complete the transaction, taking into account, among other things, the age, condition and performance of the System and advances in solar technology, provided that installed equipment shall be valued on an installed basis, shall not be valued as scrap if it is functioning and in good condition and costs of removal from a current location shall not be a deduction from the valuation, and (ii) for any given Contract Year, the amount set forth on Exhibit 4, Attachment A attached hereto. Seller shall determine Fair Market Value within thirty (30) days after Purchaser has exercised its option to Purchase the System. Seller shall give written notice to Purchaser of such determination, along with a full explanation of the calculation of Fair Market Value, including without limitation, an explanation of all assumptions, figures and values used in such calculation and factual support for such assumptions, figures and values. If Purchaser reasonably objects to Seller’s determination of Fair Market Value within thirty (30) days after Seller has provided written notice of such determination, the Parties shall select a nationally recognized independent appraiser with experience and expertise in the solar photovoltaic industry to determine the Fair Market Value of the System. Such appraiser shall act reasonably and in good faith to determine the Fair Market Value of the System based on the formulation set forth herein, and shall set forth such determination in a written opinion delivered to the Parties. The valuation made by the appraiser shall be binding upon the Parties in the absence of fraud or manifest error. The costs of the appraisal shall be borne by the Parties equally. Upon purchase of the System, Purchaser will assume complete responsibility for the operation and maintenance of the System and liability for the performance of the System, and Seller shall have no further liabilities or obligations hereunder.

18. **Indemnification and Limitations of Liability.**

- a. **General.** Each Party (the “**Indemnifying Party**”) shall defend, indemnify and hold harmless the other Party and the directors, officers, shareholders, partners, members, agents and employees of such other Party, and the respective affiliates of each thereof (collectively, the “**Indemnified Parties**”), from and against all third party loss, damage, expense, liability and other claims, including court costs and reasonable attorneys’ fees (collectively, “**Liabilities**”)

arising directly out of the performance of a Party's obligations under this Agreement or the breach of any representation or warranty set forth in Section 15 and resulting in injury to or death of persons, and damage to or loss of property to the extent caused by or arising out of the negligent acts or omissions of, or the willful misconduct of, the Indemnifying Party (or its contractors, agents or employees) in connection with this Agreement; provided, however, that nothing herein shall require the Indemnifying Party to indemnify the Indemnified Party for any Liabilities to the extent caused by or arising out of the negligent acts or omissions of, or the willful misconduct of, the Indemnified Party. This Section 18.a however, shall not apply to liability arising from any form of hazardous substances or other environmental contamination, such matters being addressed exclusively by Section 18.c; provided, however, the Purchaser expressly reserves all immunity and discretionary rights, defenses and protections as provided by Maine law, including but not limited to the Maine Tort Claims Act. The terms of this Section 18.a shall survive termination of this Agreement.

- b. **Notice and Participation in Third Party Claims.** The Indemnified Party shall give the Indemnifying Party written notice with respect to any Liability asserted by a third party (a "**Claim**"), as soon as possible upon the receipt of information of any possible Claim or of the commencement of such Claim. The Indemnifying Party may assume the defense of any Claim, at its sole cost and expense, with counsel designated by the Indemnifying Party and reasonably satisfactory to the Indemnified Party. The Indemnified Party may, however, select separate counsel if both Parties are defendants in the Claim and such defense or other form of participation is not reasonably available to the Indemnifying Party. The Indemnifying Party shall pay the reasonable attorneys' fees incurred by such separate counsel until such time as the need for separate counsel expires. The Indemnified Party may also, at the sole cost and expense of the Indemnifying Party, assume the defense of any Claim if the Indemnifying Party fails to assume the defense of the Claim within a reasonable time. Neither Party shall settle any Claim covered by this Section 18.b unless it has obtained the prior written consent of the other Party, which consent shall not be unreasonably withheld or delayed. The Indemnifying Party shall have no liability under this Section 18.b for any Claim for which such notice is not provided if that the failure to give notice prejudices the Indemnifying Party.
- c. **Environmental Indemnification.** Seller shall indemnify, defend and hold harmless all of Purchaser's Indemnified Parties from and against all Liabilities arising out of or relating to the existence at, on, above, below or near the Premises of any Hazardous Substance (as defined in Section 18.c.i) to the extent deposited, spilled or otherwise caused by Seller or any of its contractors or agents. Purchaser shall indemnify, defend and hold harmless all of Seller's Indemnified Parties from and against all Liabilities arising out of or relating to the existence at, on, above, below or near the Premises of any Hazardous Substance, except to the extent deposited, spilled or otherwise caused by Seller or any of its contractors or agents. Each Party shall promptly notify the other Party if it becomes aware of any Hazardous Substance on or about the Premises or the Premises generally or any deposit, spill or release of any Hazardous Substance. Provided, however, the Purchaser expressly reserves all immunity and discretionary rights, defenses and protections as provided by Maine law, including but not limited to the Maine Tort Claims Act.
- i. "**Hazardous Substance**" means any chemical, waste or other substance (A) which now or hereafter becomes defined as or included in the definition of "hazardous substances," "hazardous wastes," "hazardous materials," "extremely hazardous wastes," "restricted hazardous wastes," "toxic substances," "toxic pollutants," "pollution," "pollutants," "regulated substances," or words of similar import under any laws pertaining to the environment, health, safety or welfare, (B) which is declared to be hazardous, toxic, or polluting by any Governmental Authority, (C) exposure to which is now or hereafter prohibited, limited or regulated by any Governmental Authority, (D) the storage, use, handling, disposal or release of which is restricted or regulated by any Governmental Authority, or (E) for which remediation or cleanup is required by any Governmental Authority.
- d. **Limitations on Liability.**
- i. **No Consequential Damages.** Except with respect to indemnification for third party claims pursuant to this Section 18 and damages that result from the willful misconduct of a Party, neither Party nor its directors, officers, shareholders, partners, members, agents and employees subcontractors or suppliers shall be liable for any indirect, special, incidental, exemplary, or consequential loss or damage of any nature arising out of their performance or non-performance hereunder even if advised of such. The Parties agree that (1) in the event that Seller is required to recapture any Tax Credits or other tax benefits as a result of a breach of this Agreement by Purchaser, such recaptured amount shall be deemed to be direct and not indirect or consequential damages, and (ii) in the event that Seller is retaining the Environmental Attributes produced by the System, and a breach of this Agreement by Purchaser causes Seller to lose the benefit of sales of such Environmental Attributes to third parties, the amount of such lost sales shall be direct and not indirect or consequential damages. Further, the damages set forth under this Agreement, including but not limited to

any applicable Termination Payment, will not be deemed indirect, special, incidental, exemplary, or consequential.

- ii. Actual Damages. Except with respect to indemnification for third party claims pursuant to Section 18, available insurance coverage pursuant to Section 16(b)(i), and damages that result from the negligence or the willful misconduct of Seller, Seller's aggregate liability under this Agreement arising out of or in connection with the performance or non-performance of this Agreement shall not exceed the total payments made (or, as applicable, projected to be made) by Purchaser under this Agreement.

19. Force Majeure.

- a. "Force Majeure" means any event or circumstances beyond the reasonable control of and without the fault or negligence of the Party claiming Force Majeure. It shall include, without limitation, failure or interruption of the production, delivery or acceptance of electricity due to: an act of god; war (declared or undeclared); sabotage; riot; insurrection; civil unrest or disturbance; military or guerilla action; terrorism; economic sanction or embargo; civil strike, work stoppage, slow-down, or lock-out; explosion; fire; earthquake; hurricane; flood; lightning; wind; drought; the binding order of any Governmental Authority (provided that such order has been resisted in good faith by all reasonable legal means); the failure to act on the part of any Governmental Authority (provided that such action has been timely requested and diligently pursued); unavailability of electricity from the utility grid, equipment, supplies or products (but not to the extent that any such availability of any of the foregoing results from the failure of the Party claiming Force Majeure to have exercised reasonable diligence); and failure of equipment not utilized by or under the control of the Party claiming Force Majeure.
- b. Except as otherwise expressly provided to the contrary in this Agreement, if either Party is rendered wholly or partly unable to timely perform its obligations under this Agreement because of a Force Majeure event, that Party shall be excused from the performance affected by the Force Majeure event (but only to the extent so affected) and the time for performing such excused obligations shall be extended as reasonably necessary; provided, that: (i) the Party affected by such Force Majeure event, as soon as reasonably practicable after obtaining knowledge of the occurrence of the claimed Force Majeure event, gives the other Party prompt oral notice, followed by a written notice reasonably describing the event; (ii) the suspension of or extension of time for performance is of no greater scope and of no longer duration than is required by the Force Majeure event; and (iii) the Party affected by such Force Majeure event uses all reasonable efforts to mitigate or remedy its inability to perform as soon as reasonably possible. The Term shall be extended day for day for each day performance is suspended due to a Force Majeure event.
- c. Notwithstanding anything herein to the contrary, the obligation to make any payment due under this Agreement shall not be excused by a Force Majeure event that solely impacts Purchaser's ability to make payment.
- d. If a Force Majeure event continues for a period of one-hundred and twenty (120) days or more within a twelve (12) month period and prevents a material part of the performance by a Party hereunder, then at any time during the continuation of the Force Majeure event, the Party not claiming the Force Majeure shall have the right to terminate this Agreement without fault or further liability to either Party (except for amounts accrued but unpaid).
- e. The Parties acknowledge that the pricing set forth in this Agreement is predicated on the availability of photovoltaic equipment at current free-market prices. In the event that tariffs, import fees, trade duties or other new charges are imposed on such equipment after the Effective Date, whether by the Government of the United States, the U.S. International Trade Commission (USITC) or any other entity, and whether as a result of USITC Investigation No. TA-201-75, initiated on May 17, 2017 by Suniva, Inc., or for other reasons, then Seller shall be entitled to propose in writing a price adjustment to this Agreement to equitably compensate Seller for its increased costs resulting from such tariffs, fees, duties or charges. In the event Purchaser does not accept such proposed adjustment to the Contract Price, Seller shall be entitled to terminate this Agreement without further liability.

20. Assignment and Financing.

- a. Assignment. This Agreement may not be assigned in whole or in part by either Party without the prior written consent of the other Party, which consent shall not be unreasonably withheld or delayed. Notwithstanding the foregoing, Seller may, without the prior written consent of Purchaser, (i) assign, mortgage, pledge or otherwise collaterally assign its interests in this Agreement and the System to any Financing Party, and (ii) assign this Agreement and the System to an affiliate or subsidiary of Seller, ~~and (iii) assign this Agreement and the System to any person succeeding to all or substantially all of the assets of Seller;~~ (provided that Seller shall be released from liability hereunder as a result of any of the foregoing permitted assignments only upon assumption of Seller's obligations hereunder by the assignee,

and in the event of any such assignment, under (ii) or (iii), assignee has demonstrated to Purchaser's reasonable satisfaction that assignee has comparable experience in operating and maintaining photovoltaic solar systems comparable to the System and providing services comparable to those contemplated by this Agreement and has the financial capability to maintain the System and provide the services contemplated by this Agreement in the manner required by this Agreement. Purchaser's consent to such assignment shall not be unreasonably withheld. However, any assignment of Seller's right and/or obligations under this Agreement shall not result in any change to Purchaser's rights and obligations under this Agreement. This Agreement shall be binding on and inure to the benefit of the successors and permitted assignees.

- b. **Financing.** The Parties acknowledge that Seller may obtain construction and long-term financing or other credit support from one or more Financing Parties. "**Financing Parties**" means person or persons providing construction or permanent financing to Seller in connection with construction, ownership, operation and maintenance of the System, or if applicable, means, if applicable, any person to whom Seller has transferred the ownership interest in the System, subject to a leaseback of the System from such person. Both Parties agree in good faith to consider and to negotiate changes or additions to this Agreement that may be reasonably requested by the Financing Parties; provided, that such changes do not alter in a material manner any of the economic terms of this Agreement. In connection with an assignment pursuant to Section 20.a(i)-(iii), Purchaser agrees to execute any consent, estoppel or acknowledgement in form and substance reasonably acceptable to Purchaser.
- c. **Successor Servicing.** The Parties further acknowledge that in connection with any construction or long term financing or other credit support provided to Seller or its affiliates by Financing Parties, that such Financing Parties may require that Seller or its affiliates appoint a third party to act as backup or successor provider of operation and maintenance services with respect to the System and/or administrative services with respect to this Agreement (the "**Successor Provider**"). Purchaser agrees to accept performance from any Successor Provider so appointed so long as such Successor Provider performs in accordance with the terms of this Agreement.

21. [Intentionally Omitted]

22. **Goodwill and Publicity.** Neither Party shall use any name, trade name, service mark or trademark of the other Party in any promotional or advertising material without the prior written consent of such other Party. Neither Party shall make any public statements that inaccurately reflect the rights and obligations of the Parties under this Agreement, including the ownership of Environmental Attributes and Environmental Incentives and any related reporting rights.

23. **Miscellaneous Provisions**

- a. **Choice of Law.** The law of the State of Maine shall govern this Agreement without giving effect to conflict of laws principles.
- b. **Arbitration and Attorneys' Fees.** The Parties shall negotiate in good faith and attempt to resolve any dispute, controversy or claim arising out of or relating to this Agreement (a "Dispute") within 30 days after the date that a Party gives written notice of such Dispute to the other Party. If, after such negotiation, the Dispute remains unresolved, and if the Parties mutually agree, Disputes arising in connection with or under this Agreement, may be finally resolved by binding arbitration administered by the American Arbitration Association under its Construction Industry Arbitration Rules/Fast Track Procedures. Unless otherwise agreed in writing by the Parties, any Dispute proceeding shall be held in Cumberland County, Maine. If binding arbitration is approved by both Parties in writing, any such decision rendered by the arbitrator shall be final, binding, and non-appealable. If the Parties agree, a mediator may be consulted prior to arbitration. The prevailing party in any dispute arising out of this Agreement shall be entitled to reasonable attorneys' fees and costs.
- c. **Notices.** All notices under this Agreement shall be in writing and shall be by personal delivery, facsimile transmission, electronic mail, overnight courier, or regular, certified, or registered mail, return receipt requested, and deemed received upon personal delivery, acknowledgment of receipt of electronic transmission, the promised delivery date after deposit with overnight courier, or five (5) days after deposit in the mail. Notices shall be sent to the person identified in this Agreement at the addresses set forth in this Agreement or such other address as either party may specify in writing. Each party shall deem a document faxed, emailed or electronically sent in PDF form to it as an original document.
- d. **Survival.** Provisions of this Agreement that should reasonably be considered to survive termination of this Agreement shall survive. For the avoidance of doubt, surviving provisions shall include, without limitation, Section 8.g (Liens and Payment of Contractors and Suppliers), Section 8.h (No Warranty), Section 15 (Representations and Warranties), Section 16.b (Insurance Coverage), Section 18 (Indemnification and Limitations of Liability), Section 23.a (Choice

of Law), Section 23.b (Arbitration and Attorneys' Fees), Section 23.c (Notices), Section 23.g (Comparative Negligence), Section 23.h (Non-Dedication of Facilities), Section 23.m (Service Contract), Section 23.n (No Partnership), Section 23.o (Full Agreement, Modification, Invalidity, Counterparts, Captions) and Section 23.q (No Third Party Beneficiaries).

- e. **Further Assurances.** Each of the Parties hereto agree to provide such information, execute and deliver any instruments and documents and to take such other actions as may be necessary or reasonably requested by the other Party which are not inconsistent with the provisions of this Agreement and which do not involve the assumptions of obligations other than those provided for in this Agreement, to give full effect to this Agreement and to carry out the intent of this Agreement.
- f. **Right of Waiver.** Each Party, in its sole discretion, shall have the right to waive, defer or reduce any of the requirements to which the other Party is subject under this Agreement at any time (other than with respect to and/or relating to the obligation to make any payment due under this Agreement); provided, however that neither Party shall be deemed to have waived, deferred or reduced any such requirements unless such action is in writing and signed by the waiving Party. No waiver will be implied by any usage of trade, course of dealing or course of performance. A Party's exercise of any rights hereunder shall apply only to such requirements and on such occasions as such Party may specify and shall in no event relieve the other Party of any requirements or other obligations not so specified. No failure of either Party to enforce any term of this Agreement will be deemed to be a waiver. No exercise of any right or remedy under this Agreement by Purchaser or Seller shall constitute a waiver of any other right or remedy contained or provided by law. Any delay or failure of a Party to exercise, or any partial exercise of, its rights and remedies under this Agreement shall not operate to limit or otherwise affect such rights or remedies. Any waiver of performance under this Agreement shall be limited to the specific performance waived and shall not, unless otherwise expressly stated in writing, constitute a continuous waiver or a waiver of future performance.
- g. **Comparative Negligence.** It is the intent of the Parties that where negligence is determined to have been joint, contributory or concurrent, each Party shall bear the proportionate cost of any Liability.
- h. **Non-Dedication of Facilities.** Nothing herein shall be construed as the dedication by either Party of its facilities or equipment to the public or any part thereof. Neither Party shall knowingly take any action that would subject the other Party, or other Party's facilities or equipment, to the jurisdiction of any Governmental Authority as a public utility or similar entity. Neither Party shall assert in any proceeding before a court or regulatory body that the other Party is a public utility by virtue of such other Party's performance under this agreement. If Seller is reasonably likely to become subject to regulation as a public utility, then the Parties shall use all reasonable efforts to restructure their relationship under this Agreement in a manner that preserves their relative economic interests while ensuring that Seller does not become subject to any such regulation. If the Parties are unable to agree upon such restructuring, Seller shall have the right to terminate this Agreement without further liability, and Seller shall remove the System in accordance with Section 11 of this Agreement.
- i. **Estoppel.** Either Party hereto, without charge, at any time and from time to time, within five (5) business days after receipt of a written request by the other party hereto, shall deliver a written instrument, duly executed, certifying to such requesting party, or any other person specified by such requesting Party: (i) that this Agreement is unmodified and in full force and effect, or if there has been any modification, that the same is in full force and effect as so modified, and identifying any such modification; (ii) whether or not to the knowledge of any such party there are then existing any offsets or defenses in favor of such party against enforcement of any of the terms, covenants and conditions of this Agreement and, if so, specifying the same and also whether or not to the knowledge of such party the other party has observed and performed all of the terms, covenants and conditions on its part to be observed and performed, and if not, specifying the same; and (iii) such other information as may be reasonably requested by the requesting Party. Any written instrument given hereunder may be relied upon by the recipient of such instrument, except to the extent the recipient has actual knowledge of facts contained in the certificate.
- j. **Capacity & Ancillary Services.** Seller shall be entitled to receive any payments for electric capacity (including savings in the form of reduced demand charges) or ancillary services that may become available as a result of the construction or operation of the System. Purchaser shall provide reasonable assistance to Seller in order for Seller to receive such payments, and if Purchaser is deemed to be the owner or provider of such capacity or services, Purchaser shall assign the same to Seller, provided that Seller shall be responsible for the preparation and submission of any necessary applications or other documents. If Purchaser receives any payments in respect of capacity or such services it shall promptly pay them over to Seller.
- k. **No Resale of Electricity.** Except as contemplated by the provisions of this Agreement, the electricity purchased by Purchaser from Seller under this Agreement shall not be resold, assigned or otherwise transferred to any other person

without prior approval of the Seller, which approval shall not be unreasonably withheld, and Purchaser shall not take any action which would cause Purchaser or Seller to become a utility or public service company.

- l. Seller Is Not A Utility.** Neither Party shall assert that Seller is an electric utility or public service company or similar entity that has a duty to provide service, is subject to rate regulation, or is otherwise subject to regulation by any governmental authority as a result of Seller's obligations or performance under this Agreement.
- m. Service Contract.** The Parties intend this Agreement to be a "service contract" within the meaning of Section 7701(e)(3) of the Internal Revenue Code of 1986. Purchaser will not take the position on any tax return or in any other filings suggesting that it is anything other than a purchase of electricity from the System.
- n. No Partnership.** No provision of this Agreement shall be construed or represented as creating a partnership, trust, joint venture, fiduciary or any similar relationship between the Parties. No Party is authorized to act on behalf of the other Party, and neither shall be considered the agent of the other.
- o. Full Agreement, Modification, Invalidity, Counterparts, Captions.** This Agreement, together with any Exhibits, completely and exclusively states the agreement of the Parties regarding its subject matter and supersedes all prior proposals, agreements, or other communications between the Parties, oral or written, regarding its subject matter. This Agreement may be modified only by a writing signed by both Parties. If any provision of this Agreement is found unenforceable or invalid, such unenforceability or invalidity shall not render this Agreement unenforceable or invalid as a whole. In such event, such provision shall be changed and interpreted so as to best accomplish the objectives of such unenforceable or invalid provision within the limits of applicable law. This Agreement may be executed in any number of separate counterparts and each counterpart shall be considered an original and together shall comprise the same Agreement. The captions or headings in this Agreement are strictly for convenience and shall not be considered in interpreting this Agreement.
- p. Forward Contract.** The transaction contemplated under this Agreement constitutes a "forward contract" within the meaning of the United States Bankruptcy Code, and the Parties further acknowledge and agree that each Party is a "forward contract merchant" within the meaning of the United States Bankruptcy Code.
- q. No Third Party Beneficiaries.** This Agreement and all rights hereunder are intended for the sole benefit of the Parties hereto and shall not imply or create any rights on the part of, or obligations to, any other Person, except for Financing Parties permitted under Section 20 and then only as to Section 20.
- r. Bonding.**

 - i. Performance bond liability.** Any performance bond issued for a site or system will cease one (1) year from the completion of construction. If a warranty or guarantee is provided under the terms of this Agreement, the balance of any warranty or guarantee beyond one year term of the applicable performance bond shall continue to be guaranteed solely by Seller under the terms of this Agreement. The performance bond does not guarantee any property restorative requirements.
 - ii. Payment bond liability.** Any payment bond issued will cease at the termination of any time required by law.
 - iii. Performance Guarantee.** Neither payment bonds, whether for labor or materials, nor performance bonds are applicable to any specified performance guarantee.

Exhibit 4
Attachment A
Termination Payment

Contract Year	Termination Payment Amount	Fair Market Value
1	Section 14.b.iii.A	
2	Section 14.b.iii.A	
3	Section 14.b.iii.A	
4	Section 14.b.iii.A	
5	Section 14.b.iii.A	
6	Section 14.b.iii.A	
7	Section 14.b.iii.A	\$77,826
8	Section 14.b.iii.A	\$74,076
9	Section 14.b.iii.A	\$70,081
10	Section 14.b.iii.A	\$65,833
11	Section 14.b.iii.A	\$61,325
12	Section 14.b.iii.A	\$56,548
13	Section 14.b.iii.A	\$51,494
14	Section 14.b.iii.A	\$46,156
15	Section 14.b.iii.A	\$40,523
16	Section 14.b.iii.A	\$34,586
17	Section 14.b.iii.A	\$28,337
18	Section 14.b.iii.A	\$21,764
19	Section 14.b.iii.A	\$14,857
20	Section 14.b.iii.A	\$7,606
After Year 20	Fair Market Value	Fair Market Value

End of Exhibit 4

Exhibit 5
Form of Memorandum of License

NOTICE OF GRANT OF INTEREST IN REALTY

Notice is hereby given that pursuant to a Solar Power Purchase Agreement between the parties listed below, dated as of [_____] (the “**Solar Agreement**”), such Solar Agreement includes the grant of License to Seller, pursuant to the terms of the Solar Agreement (the “**License**”). This notice may be executed in counterparts by the Parties to the Solar Agreement.

Parties to the Solar Agreement:

Seller: ReVision Investments, LLC
 c/o ReVision Energy LLC
 142 Presumpscot St.
 Portland, ME 04103

Purchaser: Town of Chebeague Island
 192 North Road
 Chebeague Island, ME 04017
 Attention: Town Administrator

Date of Execution of Solar Agreement: [_____]

Description of Premises: A portion of the property described in a deed recorded in the **Cumberland County Registry of Deeds in Book _____, Page _____.**

TERM OF AGREEMENT:

The term of the License shall be until the last day of the calendar month in which the twentieth (20th) anniversary of the Commercial Operation Date (as that term is defined in the Solar Agreement) occurs, subject to any Additional Terms or early termination pursuant to the terms of the Solar Agreement.

[signature pages follow]

IN WITNESS WHEREOF, this Notice has been executed and delivered under seal on this _____ day of _____, 20__ .

GRANTOR:
INHABITANTS OF THE TOWN OF CHEBEAGUE ISLAND

By: _____
Print Name: _____
Title: _____

STATE OF _____ :
ss.
COUNTY OF _____ :

Be it Remembered, that on this ___ day of _____, 20__, before me, a Notary Public in and for the State and County aforesaid, personally appeared _____, who acknowledged him/herself to be _____ of _____, and that he/she as such _____, being authorized to do so, executed the foregoing instrument for the purposes therein contained.

IN WITNESS WHEREOF, I have hereunto set my hand and official seal.

Notary Public
My Commission expires:

GRANTEE:
REVISION INVESTMENTS, LLC

By: _____
Print Name: _____
Title: _____

STATE OF _____ :
ss.
COUNTY OF _____ :

Be it Remembered, that on this ___ day of _____, 20__, before me, a Notary Public in and for the State and County aforesaid, personally appeared _____, who acknowledged him/herself to be _____ of _____, and that he/she as such _____, being authorized to do so, executed the foregoing instrument for the purposes therein contained.

IN WITNESS WHEREOF, I have hereunto set my hand and official seal.

Notary Public
My Commission expires:

[FOR FORM PURPOSES ONLY – DO NOT EXECUTE]

End of Exhibit 5

Exhibit 6
License Agreement

This LICENSE AGREEMENT (this “**Agreement**”) is made and entered into this ____ day of _____, 2017 (the “**Effective Date**”), by and between the Town of Chebeague Island (“**Town**”), a town in the State of Maine with a mailing address of 192 North Road, Chebeague Island, ME 04017 and ReVision Investments, LLC (“**Licensee**”), a Maine Limited Liability Company with a mailing address of 142 Presumpscot St., Portland, Maine 04103.

Recitals

A. Town is the owner of those certain parcels or tracts of land located in the Town of Chebeague Island, County of Cumberland, State of Maine being a portion of the property described in a deed dated _____ and recorded in Book _____, Page _____ of the Cumberland County Registry of Deeds and more particularly shown on **Attachment A** attached hereto and incorporated herein and including the existing driveway (all of which parcels or tracts of land are referred to herein as the “**Premises**”).

B. Town and Licensee entered into a certain Solar Power Purchase Agreement (the “**Solar Agreement**”) dated _____, 2017 pursuant to which Licensee has agreed to design, construct, install, operate and maintain a certain solar photovoltaic system on a portion of the Premises (the “**System**”) for the purpose of providing electric energy to the Town.

C. Subject to the terms and conditions set forth herein, Town desires to grant to Licensee the rights described herein for the purposes of designing, installing, operating, maintaining and removing the System on and from the Premises.

Agreement

NOW, THEREFORE, in consideration of the foregoing, the mutual covenants and agreements set forth below, and other good and valuable consideration, receipt and sufficiency of which is hereby acknowledged and confirmed by Town, Town and Licensee hereby agree as follows:

1. **Grant of License.** Subject to the terms and conditions of the Solar Agreement, Town hereby grants unto Licensee, its successors and assigns, a non-exclusive license for the period of time set forth herein, across, over, under and above the portions of the Premises and Facility as depicted in Attachment A as necessary to construct, install, alter, protect, repair, maintain, replace, operate, maintain and remove the System, including any related interconnection equipment and any facilities or equipment appurtenant thereto as Licensee may from time to time require. Town also hereby grants and conveys unto Licensee all other licenses across, over, under and above the Premises as reasonably necessary to provide access to and services reasonably required for Licensee’s performance under the Solar Agreement. The licenses granted hereunder shall run with and burden the Premises for the term of this Agreement.
2. **Term.** This Agreement shall be for a period commencing on the Effective Date and expiring on the date that is the earlier of (a) the thirtieth (30th) anniversary of the Effective Date, and (b) one hundred twenty (120) days following expiration or earlier termination of the Solar Agreement. No delay or interruption by Licensee in the use or enjoyment of any right or license hereby granted shall result in the loss, limitation or abandonment of any of the rights granted hereby.
3. **Obstructions.** In addition to the rights afforded Licensee under the Solar Agreement, and subject to the terms and conditions set forth therein, Licensee, with the Town’s prior written consent, which shall not be unreasonably withheld, delayed, or conditioned, may from time to time remove structures, trees, bushes, or other obstructions within such portions of the Facility, and may level and grade such portions of the Premises, to the extent reasonably necessary to carry out the purposes set forth herein. The Town covenants for itself, its heirs, successors and assigns that:
 - a. The Town will not build or place, or allow to be built or placed, any structure or obstruction of any kind within such portions of the Premises on which is located any portion of the System, including any related interconnection equipment; and
 - b. If such a structure or obstruction is built or placed within any portion of the Premises on which is located any portion of the System, including any related interconnection equipment, the Town will remove the same at the request of the Licensee at no cost to the Licensee. The Licensee may erect a fence on such portions of the Premises or the Facility on which any portion of the System, are located in order to exclude the Town and others from accessing such areas provided that the Town gives its prior written consent, such consent not to be unreasonably withheld, delayed or conditioned.

4. **Reservation of Rights.** The Town reserves the right to use or authorize others to use the Premises in any manner not inconsistent with or which will not unreasonably interfere with the rights granted herein, provided, however, that the Town shall not, nor shall willingly permit others to, disturb the System, including any related interconnection equipment, in any way without prior written approval of the Licensee. This instrument is a License and no provision hereof shall be construed as conveying an easement or other estate in land. The Town reserves all other rights not inconsistent or incompatible with the rights granted herein to Licensee. Licensee acquires no other rights in and to the Premises, except as set forth herein.
5. **Title.** The Town represents and warrants to Licensee that (a) the Town holds fee simple title to the Premises, free and clear of all liens and any other encumbrances, and (b) no lien or other encumbrance to which the Premises is subject would reasonably be expected to adversely impact Licensee's rights hereunder or under the Solar Agreement. The Town further represents and warrants to Licensee that the Town has the right to execute and deliver this Agreement and to grant to Licensee the licenses and other rights hereunder, and that such grant does not, and will not, violate or breach the Town's organizational documents, any law, rule or regulation, or any contract, agreement or arrangement to which the Town is a party or by or to which any of the Town's assets or properties, including the Premises, is bound or subject. In the event that, after the date of this Agreement, the Town duly grants a mortgage for additional value (the "**Subsequent Mortgage**"), the Town shall, prior to and as a condition to the effectiveness of such grant of a mortgage, cause the mortgagee under the Subsequent Mortgage to execute and deliver to the Licensee an agreement, in customary form and in form and substance reasonably acceptable to Licensee, acknowledging the subordination of the Subsequent Mortgage to the grant of the license pursuant to this Agreement (the "**Subordination Agreement**").
6. **Recordation; Possession.** A memorandum of this Agreement may be recorded against the Premises by Licensee at Licensee's sole cost and expense. The Town covenants and agrees, for itself and its assigns and successors, that the Licensee shall be entitled to exercise its rights under this Agreement upon execution and delivery of this Agreement by the Parties hereto, while this Agreement is in effect, whether or not this Agreement is recorded.
7. **Governing Law.** This Agreement shall be governed by, and interpreted and construed in accordance with, the laws of the State of Maine, without regard to conflicts of law principles.
8. **Severability.** All provisions of this Agreement are severable and the invalidity or unenforceability of any provision shall not affect or impair the validity or enforceability of the remaining provisions.
9. **Binding Effect; Successors and Assigns.** Licensee shall have the right to assign, apportion, or otherwise transfer any or all of its rights, benefits, privileges, and interests arising in this Agreement in accordance with the terms of the Solar Agreement. Without limiting the generality of the foregoing, the rights and obligations of the Parties shall inure to the benefit of and be binding upon their respective successors and assigns. This Agreement may be amended, modified or terminated only by written instrument, executed and acknowledged by the Parties hereto.
10. **Headings.** The headings used herein are for convenience only and are not to be used in interpreting this Agreement.
11. **Entire Agreement.** This Agreement contains the entire agreement of the Parties with respect to the subject matter hereto and supersedes any prior written or oral agreements with respect to the matters described herein.
12. **Amendments; Acknowledgments.** The Town shall cooperate in amending this Agreement from time to time to include any provision that may be reasonably requested by Licensee's lender, any assignee of rights under this Agreement, or the lender of any assignee hereunder, provided, however, that such amendments shall not result in any substantial change to the Town's rights and obligations under this Agreement or the Solar Agreement.
13. **Counterparts.** This Agreement may be executed in counterparts, each of which shall be deemed the original, but which together shall constitute one and the same instrument.

[FOR FORM PURPOSES ONLY – DO NOT EXECUTE]

[signature pages follow]

IN WITNESS WHEREOF, this License Agreement has been executed and delivered under seal on this _____ day of _____, 2017.

GRANTOR:
TOWN OF CHEBEAGUE ISLAND

By: _____
Print Name: _____
Title: _____

STATE OF _____ :
ss.
COUNTY OF _____ :

Be it Remembered, that on this ___ day of _____, 20__, before me, a Notary Public in and for the State and County aforesaid, personally appeared _____, who acknowledged him/herself to be _____ of _____, and that he/she as such _____, being authorized to do so, executed the foregoing instrument for the purposes therein contained.

IN WITNESS WHEREOF, I have hereunto set my hand and official seal.

Notary Public
My Commission expires:

GRANTEE:
REVISION INVESTMENTS, LLC

By: _____
Print Name: _____
Title: _____

STATE OF _____ :
ss.
COUNTY OF _____ :

Be it Remembered, that on this ___ day of _____, 20__, before me, a Notary Public in and for the State and County aforesaid, personally appeared _____, who acknowledged him/herself to be _____ of _____, and that he/she as such _____, being authorized to do so, executed the foregoing instrument for the purposes therein contained.

IN WITNESS WHEREOF, I have hereunto set my hand and official seal.

Notary Public
My Commission expires:

[FOR FORM PURPOSES ONLY – DO NOT EXECUTE]

**Exhibit 6
Attachment A**

Sketch of the Premises and Facility

62.1 kW_{DC} PHOTOVOLTAIC SYSTEM
ANNUAL PRODUCTION ESTIMATE: 79,516 kWh



142 PRESUMPCOT ST
PORTLAND ME 04103
(207) 221-6342

CLIENT:

TOWN OF CHEBEAGUE ISLAND

PROJECT ADDRESS:

DUMP ROAD
CHEBEAGUE ISLAND, ME 04017

SYSTEM TYPE:

PHOTOVOLTAIC ARRAY

DESIGNED BY: LB

REVISION: 0

PRINT SIZE: 17" x 11"

SCALE: 1" = 80'

DATE: AUGUST 25, 2017

DWG Title: SITE PLAN, OPTION I

DWG Number: SHEET A01.1

© COPYRIGHT REVISION ENERGY

THIS DIAGRAM IS PROVIDED AS A SERVICE AND IS BASED ON THE UNDERSTANDING OF THE INFORMATION SUPPLIED. IT IS SUBJECT TO CHANGE BASED ON ACTUAL CONDITIONS, APPLICABLE EDITION OF THE NATIONAL ELECTRIC CODE, AND LOCAL GOVERNMENTAL AUTHORITIES.

